

1 2 3 4 5 6

D

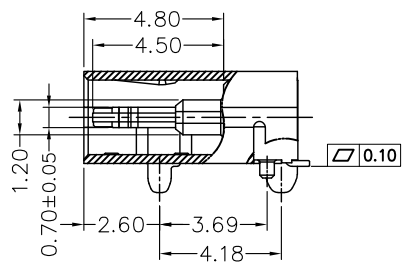
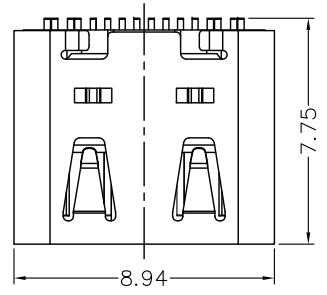

CUTAWAY

NOTE:

1. MATERIAL
See TABLE I
2. ELECTRICAL
Rating Current: 5A Up to 8A
Rating Voltage: 30V Up to 48V
Insulator Resistance: 100M ohms Min.
Withstanding Voltage: 100 VAC / minute
Contact Resistance: 40m ohms Max.(Initial)
50m ohms Max.(After Test)
Operating Temperature: -25°C to +85°C
3. MECHANICAL
Mating Force: 5N~20N
Unmating Force: 8N~20N (Initial)
6N~20N (After Durability Test)
Durability: 10,000 cycles

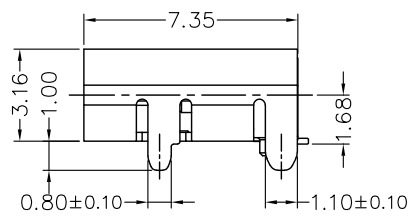
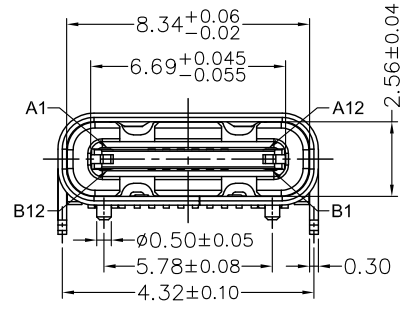

UTC1600-00-XX-06

Connector Series

G0: Gold Flash
G2: 30u"

C

B

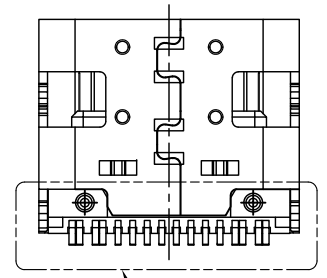

DETAIL-A

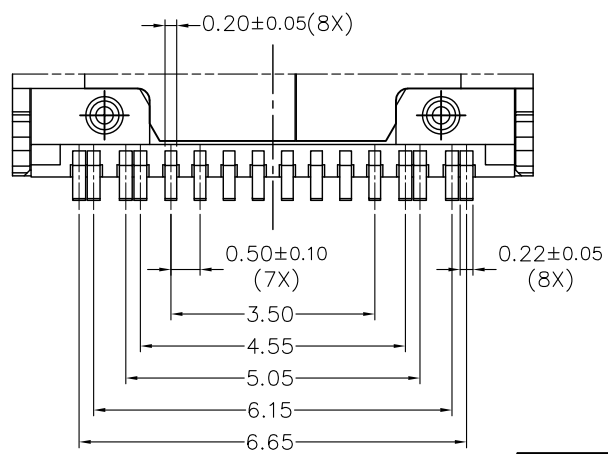

DETAIL-A
SCALE 2:1

< PIN ASSIGNMENTS >

A1	A4	A5	A6	A7	A8	A9	A12
GND	VBUS	CC1	D+	D-	SBU1	VBUS	GND
B12	B9	B8	B7	B6	B5	B4	B1
GND	VBUS	SUB2	D-	D+	CC2	VBUS	GND

A

UNLESS TOLERANCE		DRAW BY	Shun	鎡運股份有限公司 Aquatech Corporation			
GENERAL	ANGLE	DESIGN BY					
X.X ± 0.25	± 2'	CHECK BY	Ren	PART NO: UTC1600-00-XX-06			
X.XX ± 0.15		APPROVE BY	Peter	ITEM : USB 2.0 Type-C Receptacle Connector 16P			
X.XXX ± 0.10		SCALE	SHEET	UNIT	DWG NO: GL22002		
REV.	ECN. NO.	APR.	DATE	1:1	1/3	MM	REV: B

B	Revised		2022.08.31
A	New Version		2022.05.05
REV.	ECN. NO.	APR.	DATE

1 2 3 4 5 6

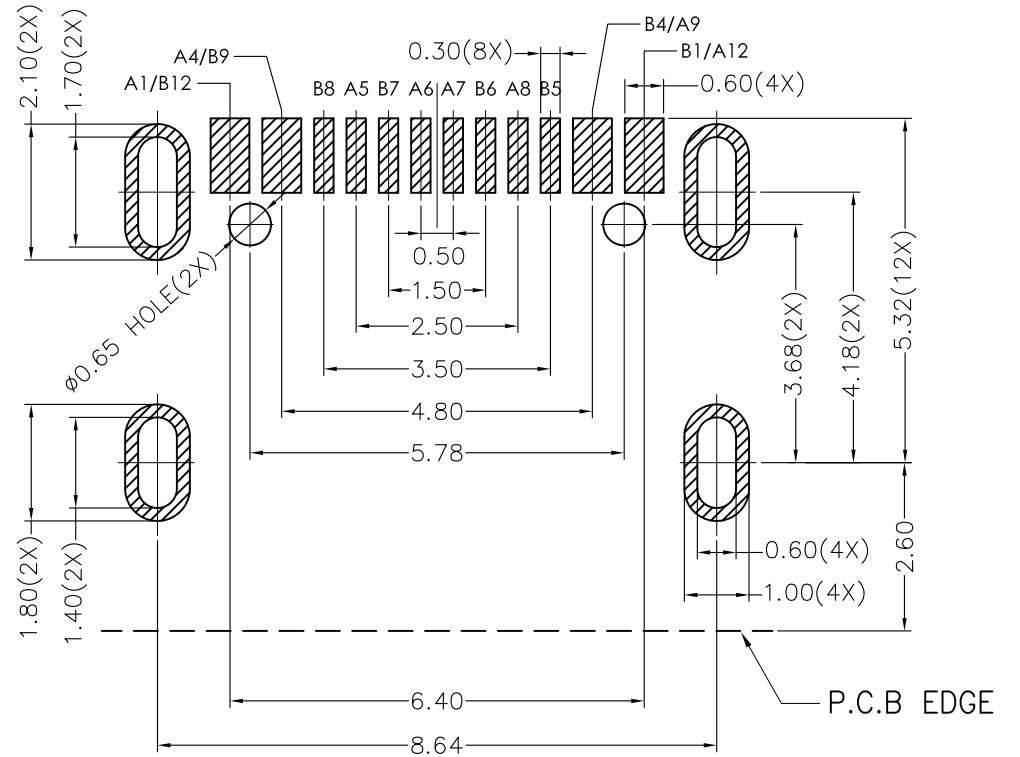
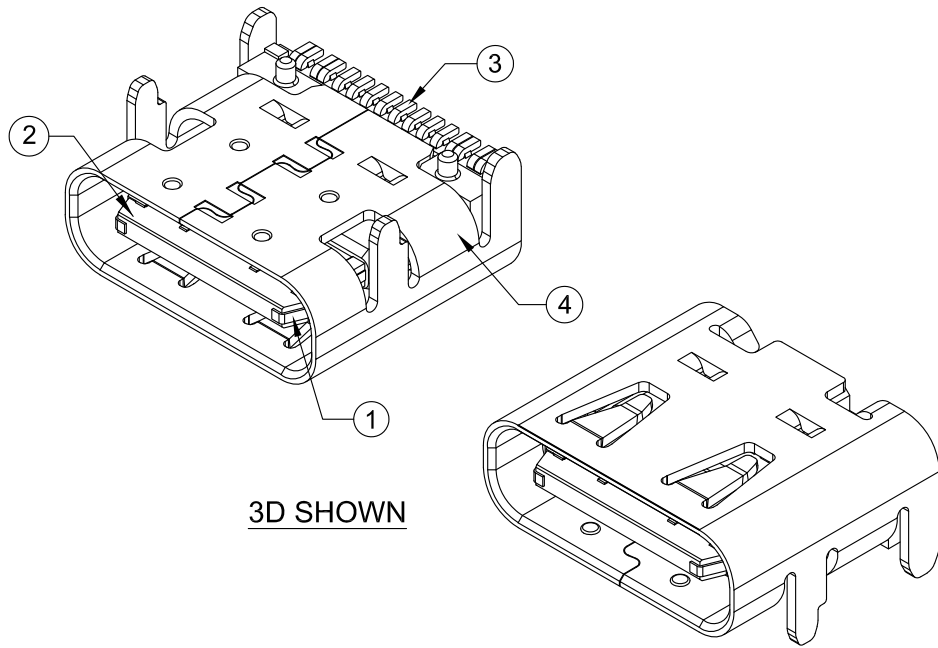

< TABLE I >

ITEM	PARTS NAME	Q'TY	MATERIAL	FINISH/REMARK
1	Housing	1	LCP	Black
2	MID-Plate	1	STAINLESS	Ni: 50 μ " Min.
3	Terminal	16	COPPER ALLOY	Contact Area : G/F Or 30 μ " Solder Tail: Tin, 50u" Nickel Overall
4	Shell	1	STAINLESS	Ni: 30 μ " Min.

UNLESS TOLERANCE		DRAW BY	Shun	鎂運股份有限公司 Aquatech Corporation PART NO: UTC1600-00-XX-06 ITEM : USB 2.0 Type-C Receptacle Connector 16P DWG NO: GL22002 REV: B	
GENERAL	ANGLE				
X.X ± 0.25	± 2'	DESIGN BY			
X.XX ± 0.15		CHECK BY	Ren		
X.XXX ± 0.10		APPROVE BY	Peter		
		SCALE	SHEET	UNIT	
		1:1	2/3	MM	

REV.	ECN. NO.	APR.	DATE
B	Revised		2022.08.31
A	New Version		2022.05.05

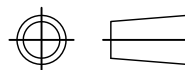

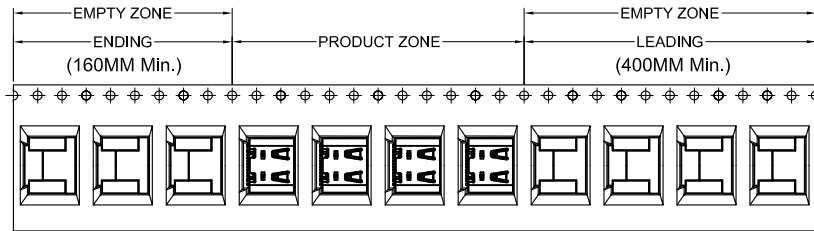

PULL OUT DIRECTION →

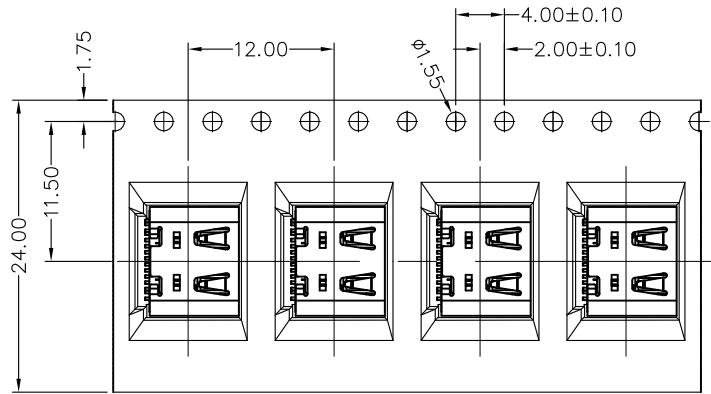
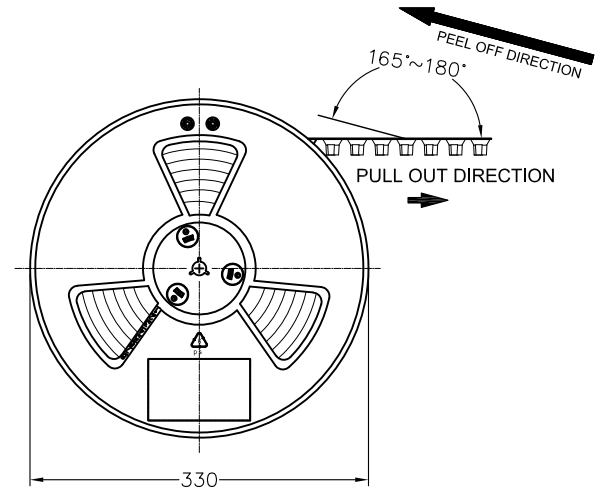

PULL OUT DIRECTION →

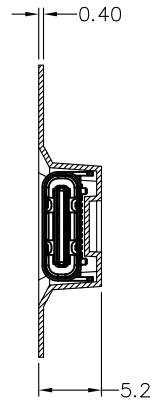

Cutaway-Y

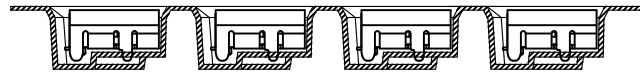

Cutaway-X

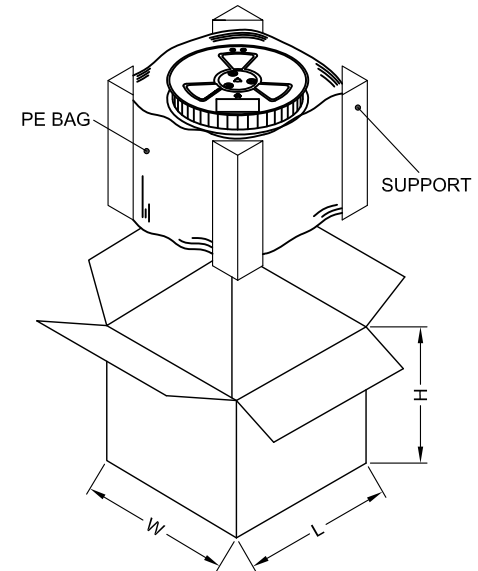

NOTE:

1. DIMENSION:

CARTON: L=340, W=340, H=310

2. QUANTITY:

900 PCS/REEL

9,000 PCS/ CARTON

UNLESS TOLERANCE	
GENERAL	ANGLE
X.X ± 0.35	± 2°
X.XX ± 0.20	
X.XXX ± 0.10	

DRAW BY	Shun
DESIGN BY	
CHECK BY	Ren
APPROVE BY	Peter
SCALE	SHEET UNIT
1:1	3/3 MM

鎡運股份有限公司 Aquatech Corporation	
PART NO: UTC1600-00-XX-06	
ITEM : USB 2.0 Type-C Receptacle Connector 16P	
DWG NO: GL22002	REV: A

A	New Version		2022.09.01
REV.	ECN. NO.	APR.	DATE

